

Exhibitor Service Manual



Thank you for choosing to exhibit at Advanced Textiles Expo. We hope the experience is successful for your company. Make the most of the show by taking advantage of valuable networking opportunities, dynamic programming and a robust show floor.

This Exhibitor Service Manual contains the information you need to prepare for a successful exhibiting experience. Keep this information handy to refer to throughout the show. Pay special attention to the Rules and Regulations to ensure the type and size of booth you have selected complies with regulations. For any questions, please take advantage of the resources listed in the Important Show Contacts section of the manual.

Installation

There will be no exceptions to the installation hours unless prior approval is received by Show Management.

Sunday, Sept. 22 | 8 am–5 pm

Monday, Sept. 23 | 8 am–5 pm

Trade Show Hours

Tuesday, Sept. 24 | 9 am–4 pm

Wednesday, Sept. 25 | 9 am–4 pm

Thursday, Sept. 26 | 9 am–1 pm

Dismantling

Exhibit policies do not permit early dismantling without prior approval from Show Management. Violations are subject to a \$500 fine. For the safety of all event participants and integrity of the show, tear down of exhibits may not begin until show close.

Thursday, Sept. 26 | 1–8 pm

Friday, Sept. 27 | 8 am–noon

NOTE: It is the responsibility of the exhibiting company to ensure that all booth personnel are familiar with the rules and regulations of this event.

Anaheim Convention Center
800 W Katella Ave.
Anaheim, CA 92802

Accommodations/Housing

advancedtextilesexpo.com/travel-hotel
AdvancedTextilesExpo@Conferencedirect.com
Phone: +1 888 872 6501
International: +1 801 903 1791

Hilton Anaheim
777 W. Convention Way
Anaheim, CA 92802 USA

Catering

Aramark
Catherine Alas
alcaraz-catherine@aramark.com
Send orders to: ACC-CATERING@ARAMARK.COM

Common Carrier/Air Freight

Freeman Transportation
Phone: +1 800 995 3579
Exhibit.transportation@freeman.com

Electrical/Plumbing/Air

Freeman
Phone: +1 888 508 5054
www.FreemanCo.com/store/faqs#contactUS

Exhibitor Meeting Spaces

Jordan Guetzlaff
Events Assistant
Advanced Textiles Association
Phone: +1 651 225 6987
Jordan.Guetzlaff@textiles.org

Furniture, Decorations and Floor Covering

Freeman
Phone: +1 888 508 5054
www.FreemanCo.com/store/faqs#contactUS

Internet/Phone

Smart City
Michelle Dolph-Gualtieri
mgualtieri@smartcity.com

Marketing

Christian Weiland
Marketing Director
Advanced Textiles Association
Phone: +1 651 225 6916
christian.weiland@textiles.org

Photography

Mark Skalny Photography
+1 888 658 3686
mark@markskalny.com
www.markskalnyphotography.com

Registration

Advanced Textiles Association
1801 County Road B W, Ste 100
Roseville, MN 55113
events@textiles.org

Storage and Material Handling

Freeman
Phone: +1 888 508 5054
www.FreemanCo.com/store/faqs#contactUS

Show Management

Katie MacKenzie
Show Floor Manager
Advanced Textiles Association
Phone: +1 651 225 6983
katie.mackenzie@textiles.org

Holly Williams
Conference Management Director
Advanced Textiles Association
Phone: +1 651 225 6934
holly.williams@textiles.org

Exhibitor Registration Options

	Emerging Technologies Conference Sept. 23-26		Advanced Textiles Expo Sept. 24-26	
	MEMBER	NON-MEMBER	MEMBER	NON-MEMBER
EARLY BIRD Through June 5	\$499	\$699	\$29	\$99
STANDARD RATES June 6-July 31	\$549	\$799	\$69	\$169
LATE/ON-SITE Begins Aug. 1	\$599	\$899	\$79	\$179
BENEFITS INCLUDE				
Opening Reception	✓		✓	
3 Days of Show Floor Access	✓		✓	
All Show floor Education	✓		✓	
Next Gen Programming	✓		✓	
Women's Networking	✓		✓	
Marine Fabricators Road Show	✓		✓	
ATA Pitch Fest	✓		✓	
ATA Textiles Challenge	✓		✓	
1 1/2 days pre-conference education dedicated to emerging technologies	✓			
Networking lunch	✓			
Emerging Technologies Networking Reception	✓			

Add-on Opportunities	MEMBER	NON-MEMBER
Industry Night Sept. 24, 7-9 pm Anaheim House of Blues: Includes: food, drinks and networking.	\$79	\$89
Fun Run Give Back Opportunity! Proceeds Benefit the Work Ethic Scholarship Program. Includes: Tshirt."	\$49	\$59

DESCRIPTIONS OF REGISTRATION PACKAGES

Advanced Textiles Expo Registration

Includes: 3 days of show floor access, multiple education sessions on the show floor, opening reception, Next Gen programming and Women's networking. Add ons: Industry Night and Fun Run.

Emerging Technologies Conference Registration

Includes: 1 1/2 days of education and networking with other Emerging Technologies professionals. Also includes Advanced Textiles Expo registration, education and networking. Add ons: Industry Night and Fun Run. Emerging Technologies Conference will be held at the Anaheim Hilton, located next to the Anaheim Convention Center. Does not include Industry Night and Fun Run.

Exhibitor Registration Options

Exhibitor Staff Badge

- » Exhibitors must register using the exhibitor registration portal to receive a registration type which will give access to the show floor as an exhibitor. Information on how to access the portal is sent to the primary booth contact.
- » Exhibitors receive 3 complimentary Booth Staff Only Registrations per 100 sq. ft. of exhibit space. Additional and upgraded exhibitor registrations are available for purchase. Co-exhibitors will not receive additional complimentary badges.
- » Exhibitors may not use VIP Discount codes for exhibit staff members.
- » Wristbands will be issued to contract staff for the sole purposes of setup and takedown. The wristbands will allow entrance to the exhibit hall during setup and takedown hours only. Wristbands will be invalid during show hours. Please have contract staff request their wristbands at registration. Please notify Show Management of all contract staff you will have present in advance of the show to assure they will be able to receive a wristband.

NOTE: If you cancel exhibitor staff badge before Monday, July 8, 2024 11:59 pm Central Time, you are eligible for a full refund; however, you will incur a cancellation fee of 10% of your total registration fees. Cancellation notifications must be emailed to Show Management at events@textiles.org before this time. Substitutions from the same company will be accepted in writing without penalty.

Upon proper cancellation, the full registration fee will be refunded, less the cancellation fee of 10% of your total registration fees, to the card associated with the original transaction.

If you cancel your exhibitor staff badge between Monday, July 8, 2024 and Friday, Aug. 30, 2024, you are eligible for a 50% refund; however, you will incur a cancellation fee of 20% of your total registration fees. Cancellation notifications must be emailed to Show Management at events@textiles.org before this time. Substitutions from the same company will be accepted in writing without penalty.

No refunds of any kind will be made for cancellations received after Friday, Aug. 30, 2024 at 11:59 pm Central Time. No refunds will be given for “no-shows”, late arrivals, early departures, and/or anyone who fails to notify Show Management by the cut-off date using the method listed above.

Unlimited uses at no cost to you! Send your company's exclusive VIP Discount codes to your customers to invite them to visit you on the show floor. When registering, your VIPs are able to apply your discount for a free Advanced Textiles Expo registration or 10% off an Emerging Technologies Conference registration.

Your exclusive VIP Discount codes will be emailed to your booth contact. To access an editable PDF to send to your customers or use in your newsletters, on a social media, or in email signatures, please visit your Exhibitor Hub at bit.ly/Expo2024Promote.



Accommodations/Housing

9/2/2024 Deadline to receive discounted rates.

Reserve Your Hotel Room Today

Visit [AdvancedTextilesExpo.com](https://www.advancedtextilesexpo.com) for more information.

Housing/Reservations Contact:

Phone: +1 801 903 1791

Toll Free: +1 888 872 6501

Email: AdvancedTextilesExpo@Conferencedirect.com

<https://book.passkey.com/go/AdvancedTextilesExpo24>

To reserve five or more hotel rooms email Julie at

julie.reilly@conferencedirect.com.

NOTE: ConferenceDirect is the ONLY official Housing company for Advanced Textiles Expo. If you are contacted by a company other than ConferenceDirect, please contact Show Management immediately at events@textiles.org. Show Management will work to prevent these companies from contacting our exhibitors and attendees.

Exhibitors are responsible for ensuring their company, personnel, and booth are compliant with all event and local rules and regulations.

EARLY DISMANTLE POLICY

No early dismantling of booths prior to the close of the show on **Thursday, Sept. 26 at 1 pm.**

NOTE: Advanced Textiles Expo exhibit policies do not permit early dismantling without prior approval from Show Management. Violations are subject to a \$500 fine, loss of booth selection priority points, and subject to additional penalties as stated in the Rules and Regulations, Item 16. For the safety of all Advanced Textiles Expo participants and integrity of the show, tear down of exhibits may not begin until show close.

In addition to Show Management regulations, exhibitors must also comply with all local rules and regulations.

1. CONTRACT FOR SPACE

The exhibit space contract properly executed by applicant (exhibitor) is subject to formal notice of acceptance by Show Management, Advanced Textiles Association, formerly Industrial Fabrics Association International (IFAI) and is subject to all conditions, terms and regulations set forth herein. Show Management reserves the right to reject any application or relocate exhibit space without assigning any cause therefore.

The exhibitor will assume the cost of any additional services/equipment required for their respective exhibit space. Exhibitor shall not assign, sublet, share or apportion the whole or any part of the space allotted, or have representatives, products, equipment, signs or printed materials from other than its own firm contracted in the assigned exhibit space without the prior written consent of Show Management.

Co-Exhibitors: Fees apply. Contact Sales Manager for complete details.

Additional Show Directory Listing: Fees apply. Contact Sales Manager for complete details.

2. PAYMENT FOR SPACE

- a. Exhibit space must be contracted with full payment or a 25% nonrefundable deposit (U.S. funds). After March 1, 2024, full payment is required to reserve exhibit space.
- b. To be eligible for the Advanced Textiles Association (formerly known as IFAI) member rate, the exhibitor must be a member of ATA in good standing throughout the duration of the event. Should an exhibitor's membership lapse, the non-member rate will apply and be due prior to the installation dates.
- c. A \$100 per month late fee will be applied to any balance not paid by March 1, 2024. All past due monies owed Show Management for any previous business transaction must be paid in full prior to being allowed on the show floor. In the event that Show Management cancels a booth due to outstanding balances, Show Management may apply booth money to those outstanding invoices.

NOTE: Payments made by wire transfers must include an additional \$25 for domestic or \$45 for international. Any past-due invoices (e.g., advertisements, material sales, etc.) that the exhibitor owes Show Management must be paid three weeks before attending the exposition or the booth space and any payment received for the booth space may be forfeited. Show Management may apply forfeited booth money to outstanding invoices at its discretion.

3. SELECTION OF EXHIBIT SPACE

Space is assigned according to a yearly point accumulation system. Exhibiting companies earn points based on criteria including, class of membership, exhibiting and total annual revenue spent with Show Management.

Companies that fail to exhibit for three consecutive years will forfeit all accumulated points.

- a. If two separate companies merge who both exhibit at the Advanced Textiles Expo, the point totals will be combined.
- b. If a company or division is sold or has merged and a new entity is not created, the points will go with the new company. If a new entity is created, then the company would start with zero points.
- c. It is against the rules and regulations for one company to reserve exhibit space for another exhibiting company in order to supercede the booth selection process, which is based on total accumulated points. Violators are subject to penalties as stated in the Rules and Regulations, Item 16.

Every effort will be made to respect the exhibitors' space choices whenever possible, but Show Management reserves the right to make other assignments when such action is deemed to be in the best interests of the total exhibit effort.

4. CANCELLATION AND REDUCTION CHARGES

In the event of a cancellation or reduction of space by an exhibitor, an assessment to cover service performed and other damages relating to the action shall be made as follows:

REDUCTION OF SPACE

Before March 1: 20% of exhibit space rate difference

After March 1: 50% of exhibit space rate difference

CANCELLATION OF SPACE DURING THE PERIOD OF

Before March 1 | 25% of the space rate

March 1-May 31 | 50% of the space rate

June 1-July 15 | 75% of the space rate

After July 15 | 100% of the space rate

It is understood that Show Management reserves the right, at its option, to reassign cancelled booths regardless of the cancellation rate assessed. Subsequent reassignment of cancelled space does not relieve the cancelling exhibitor of their obligation to pay the amount referred to above.

5. PROVIDED BY SHOW MANAGEMENT

All booths, except island booths, will have 8' high back drape and, 3' high side dividers. Booths 300 sq ft or less will receive a 7"x 44" identification sign. Booths larger than 300 sq ft may receive an identification sign upon request. All exhibitors are eligible to submit a company and product listing in the Advanced Textiles Expo Guide, mobile app, and online show floor map. Exhibitors will be provided with a no-cost VIP Discount that they can distribute to unlimited customers, contacts, and colleagues outside of the exhibiting company.

COLORS

Emerging Technologies area: White booth drape and midnight blue aisle carpet.

Specialty Fabrics area: Black booth drape and tuxedo aisle carpet.

6. INSTALLATION AND DISMANTLING

There will be no exceptions to the installation or dismantling hours unless prior written approval is received by Show Management. No person under the age of 18 is allowed on the show floor during installation and dismantling hours.

INSTALLATION

Any space not claimed and occupied three hours prior to the opening hour of the exhibit may be reassigned without refund.

Sunday, Sept. 22 | 8 am-5 pm

Monday, Sept. 23 | 8 am-5 pm

DISMANTLING

Advanced Textiles Expo exhibit policies prohibit early dismantling without prior approval from Show Management. Violations are subject penalties as stated in the Rules and Regulations, Item 16. Any display not claimed will be dismantled and stored by the exhibit service contractor at the expense of the exhibitor.

Thursday, Sept. 26 | 1-8 pm

Friday, Sept. 27 | 8 am-Noon

DECORATORS UNION

Members of this union claim jurisdiction over all set-up and dismantling of exhibits including signs and laying of carpet. This does not apply to the unpacking and placement of exhibitors' merchandise. Exhibitors may install and/or dismantle their exhibit display if one person, who is a full-time employee, can accomplish the task in an hour or less without the use of tools.

If exhibit preparation, installation or dismantling requires more than 1 hour, exhibitors must use union personnel supplied by Freeman. When union labor is required, exhibitors may provide their company personnel to work along with a union installer in Southern California on a one-to-one basis.

7. BOOTH DESIGN

Booths are required to have carpeting or floor covering. Booths without approved floor covering will be carpeted by exhibit service contractor at the expense of the exhibitor. All exposed parts of the display must be finished so as not to be objectionable or obstruct other exhibits, and the outside facing must be neutral.

NOTE: See specific booth design restrictions in the Booth Display Regulations section of Exhibitor Service Manual.

8. RESTRICTIONS AND LIMITATIONS

- A. **MATERIAL HANDLING**—The teamsters union claims jurisdiction on the operation of all material handling equipment, all unloading and reloading, and handling of empty containers. An exhibitor may move the material that is hand carriable by one person in one trip, without the use of dollies, hand trucks or other mechanical equipment.
- B. **AUDIO VISUALS**—Exhibits which include the operation of musical instruments, radios, public address systems, slide or motion picture projection or any noise-making machines must be conducted or arranged so that the noise resulting from the demonstration will not annoy or disturb adjacent exhibitors and their patrons. Operators of noise-making exhibits must secure approval from Show Management of operating methods before exhibit opens. Exhibitor is responsible for attaining appropriate music licensing through www.bmi.com/licensing or www.ascap.com/music-users if playing music at their booth in any manner. Proof of licensing must be made available upon request.
- C. **SOUND LEVEL**—Any noise generated by operating equipment, booth displays, or machinery must not exceed 80 dB when measured from a distance of 10 ft (3.05m), or be determined obtrusive by show management.
- D. **SOLICITATIONS**—No solicitations shall be permitted outside of the exhibitor's assigned space, and no signs or placards may be displayed on persons or otherwise outside exhibit space. This rule applies to all participants of Advanced Textiles Expo, unless it is a Show Management approved item. Any signs or collateral found outside the assigned exhibit space may be automatically discarded without notice.
- E. **CHARACTER OF EXHIBITS**— Show Management reserves the right to restrict, prohibit or evict any portion of an exhibit without assigning any cause therefore. This reservation covers persons, things, conducts, printed matter or anything of a character which Show Management determines should be restricted, prohibited or evicted. In the event of such restriction, prohibition or eviction, Show Management is not liable for any refunds or rentals or other exhibit expenses.

- F. **DEMONSTRATIONS**—If you expect many attendees to congregate in one area at one time, you must leave space within your own exhibit area to absorb the majority of the crowd.

Intent: The aisles are to service all exhibitors; therefore, each exhibitor has the responsibility to assure proper flow of traffic through the entire exposition. When large crowds gather to watch a demonstration or entertainment and interfere with the flow of traffic down aisles, or create excessive crowds in neighboring booths, this is an infringement on the other exhibitors' rights. Aisles must not be obstructed at any time.

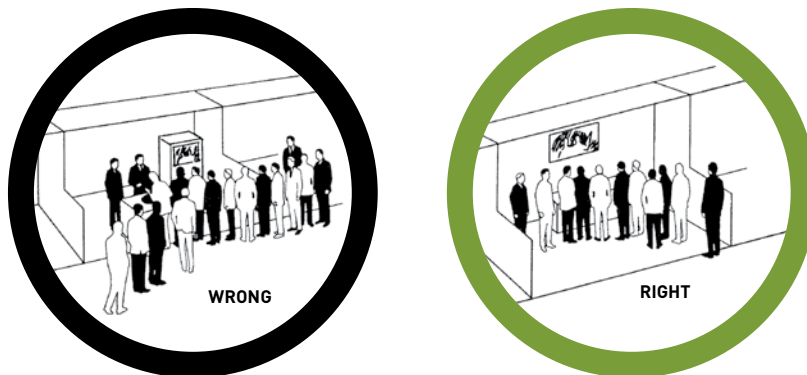

- G. **COMPLIANCE**—The Exhibitor assumes all responsibility for any compliance with all pertinent ordinances, regulations and codes of duly authorized local, state and federal governing bodies concerning fire, safety and health, together with the rules and regulations of the operators and/or owners of the property wherein the show is held.

AMERICANS WITH DISABILITIES ACT (ADA)

Exhibitors are responsible for ensuring their displays are in compliance with the Americans with Disabilities Act (ADA). Examples include, but are not limited to: ensuring an equal attendee experience is offered on all levels of a multi-story booth, exhibits being wheelchair accessible, displays are arranged at an appropriate height to accommodate a person sitting in a wheelchair. All companies are to accommodate reasonably to attendees with disabilities. Additional information is available at www.ada.gov.

- H. **LIVESTOCK**—No live animals will be allowed in the exhibits. This rule applies to all participants of the Advanced Textiles Expo.
- I. **BALLOONS**—No helium balloons will be allowed in the exhibits. This rule applies to all participants of Advanced Textiles Expo.
- J. **FOOD AND BEVERAGE**—All food and beverage must be provided by the exclusive provider.

- K. **REFUSE**—Any exhibitor that distributes or produces any type of item, such as popcorn, that produces debris in the aisle or other exhibitors booths, will be responsible for the cost of hiring porters to keep the show floor clean during show hours.
- L. **GENERATORS/AIR COMPRESSORS**—Portable generators or air compressors are subject to local ordinance and center regulations.
- M. **CAMERAS**—The taking of pictures by an exhibiting company's personnel of another exhibitor's products could result in the expulsion of the offending company from future Show Management sponsored expositions. This rule is applicable for all Show Management functions and applies to all event participants. Noncompliance will result in the confiscation of all images/ film, immediate deletion of all images on an electronic device, and possible removal from the show floor. Advanced Textiles Expo's official exposition photographer maintains rights to all professional images.
- N. **VEHICLES**—The use of vehicles for display of any type must be pre-approved by Show Management and must meet local fire and safety requirements.
- O. **STORAGE OF MATERIALS**—Fire codes restrict the storage of any type of materials behind the exhibitor's booth. Items needed by the exhibitor for packing should have empty stickers placed on them so they can be stored and returned at the close of the show. Storage of materials must meet local safety requirements.
- P. **LUGGAGE**—No luggage will be allowed on the show floor. This rule applies to all participants at Advanced Textiles Expo.
- Q. **CONVENTION CENTER RULES**—It is each exhibitor's responsibility to ensure they are in compliance with convention center rules and regulations.

9. LIABILITY

The exhibitor agrees that Show Management shall not be liable for any damage to exhibit or material during shipping or delivery to booth or damage or liability of any kind, including content of display or literature, or for any damage or injury to person or property during the term of this agreement, from any cause whatsoever by reason of use, occupation and enjoyment of exhibit space by the exhibitor or any person thereon with the consent of the exhibitor, and that the exhibitor will indemnify and hold harmless Show Management from all liability whatsoever, including all litigation expenses, court costs and attorney fees, on account of any such damage, or injury, whether or not caused by negligence or of breach an obligation by the exhibitor or its employees or representatives.

A. INSURANCE—As a standard requirement for Advanced Textiles Expo, it will be necessary for the exhibitor to carry general liability coverage from an insurance company in good standing with minimum policy limits of \$1,000,000 per occurrence and \$2,000,000 aggregate. Exhibitors must provide a certificate of liability insurance with Advanced Textiles Association, Freeman, and the convention center listed as an additional insured. As Advanced Textiles Expo's official insurance vendor, Rainprotection Insurance will be contacting exhibitors directly to collect and record compliant insurance certificates.

The primary contact for the exhibiting organization's information (name, title, email address, mailing address, country, and phone number) will be shared with Rainprotection Insurance for the sole purpose of collecting insurance certification, verifying adequate coverage, and providing an opportunity for the exhibitors to purchase coverage for this event only. To review Rainprotection's privacy policy, please visit <https://www.rainprotection.net/>.

10. LOSS OR DAMAGE

Show Management, its officers and staff members will not be responsible for the safety of the property of the exhibitors from theft, damage by fire, accident, or other causes, but will use reasonable care to protect the exhibitors from such loss and will have security personnel on duty. No responsibility is assumed for goods delivered to the exhibit area before setup day or for unpacked materials left in the exhibit area after the closing hour of the exhibit. Exhibitors wishing to insure their goods must do so at their own expense. This rule applies to all participants in the Advanced Textiles Expo.

11. MEETINGS, PRIVATE PARTIES AND TOURS

Hospitality suites, special events, meetings and tours must be approved by Show Management and may not compete/overlap with any scheduled Advanced Textiles Expo events. Further, hosted parties and tours at which attendance is restricted to either verbal or written invitation are not permitted during any official Advanced Textiles Expo activity. Meeting rooms and suites will not be released to non-exhibiting suppliers at the convention facility and/or hotels within the Advanced Textiles Expo hotel block.

12. PUBLIC ADDRESS SYSTEM

The Public Address (PA) System in the exhibit hall will be used only to announce the opening and closing of the show and matters of public safety. Other announcements will be at the discretion of Show Management.

13. EXHIBIT HALL INSPECTION

Show Management will conduct an exhibit hall inspection during exhibitor installation days at which time any violations will be noted and the exhibiting company will be required to correct said violation(s) prior to show opening. Refusal or failure may result in Show Management correcting said violation(s) at the exhibitor's expense, or possible eviction from the trade show. If you have any questions, please feel free to contact Show Management.

14. ENTERING ANOTHER EXHIBITOR'S BOOTH

No exhibit personnel of one company will enter another company's booth that is not staffed by employees of the other exhibiting company. This rule applies throughout Advanced Textiles Expo.

15. NON-EXHIBITOR SOLICITATION

Suitcasing, which is soliciting business at the exposition by non-exhibiting personnel, is strictly forbidden. Any non-exhibiting attendee who is observed to be soliciting business as a supplier will be in violation of Show Management's anti-suitcasing policy and will be asked to leave immediately and subject to additional penalties at the discretion of Show Management. Please report any suspected suitcasers to Advanced Textiles Expo Show Management.

16. PENALTIES

Any exhibitor or registrant that does not comply with the Advanced Textiles Expo Rules and Regulations as stated herein is subject, at the discretion of Show Management, to any or all of the following: loss of booth selection priority points, immediate expulsion from the event, loss of Advanced Textiles Association (formerly known as IFAI) membership, ban from exhibiting or registering at future Show Management sponsored events, confiscation of cameras and/or film, and monetary fines.

17. FORCE MAJEURE

Show Management reserves the right to change the location or cancel expositions in the event a strike, fire, war, government regulation, disaster, civil disorder, curtailment of transportation facilities, pandemic, or Act of God should render the hall in which the convention has been scheduled unusable. No refunds of exhibit space payments will be distributed until Show Management has officially declared in writing that Advanced Textiles Expo has been canceled. If Advanced Textiles Expo is cancelled and rescheduled, Exhibitor agrees that it will make its best effort to continue to participate on the rescheduled dates.

18. SPONSORSHIPS

Advanced Textiles Expo sponsorships will be offered exclusively to and purchased by contracted exhibiting companies at Advanced Textiles Expo 2024, except at the discretion of Show Management.

19. COMPLIMENTARY DISPLAY SPACE

Show Management has the right to assign complimentary display space to organizations or companies within the exhibit hall or common areas of the annual exposition. Booth furnishings, power, shipping and materials handling will be the responsibility of the exhibitor unless specified in writing by Show Management.

Exhibitors are responsible for ensuring their booth display complies with all exhibit dimension regulations. Show management will conduct an exhibit hall inspection during installation at which time any violations will be noted and the exhibiting company will be required to correct said violation(s) prior to show opening. Refusal or failure may result in penalties as stated in Item 16 in the Rules and Regulations section of the Exhibitor Service Manual.

Booth Display Regulations are designed to adhere to standard exhibit industry practices as defined in the International Association of Exhibits and Events (IAEE) Guidelines for Display Rules and Regulations.

All references to "Show Management" refers to Advanced Textiles Association's (formerly known as IFAI) Conference Management team.

Standard and Corner Booth

Exhibit in one or more units in a straight line.

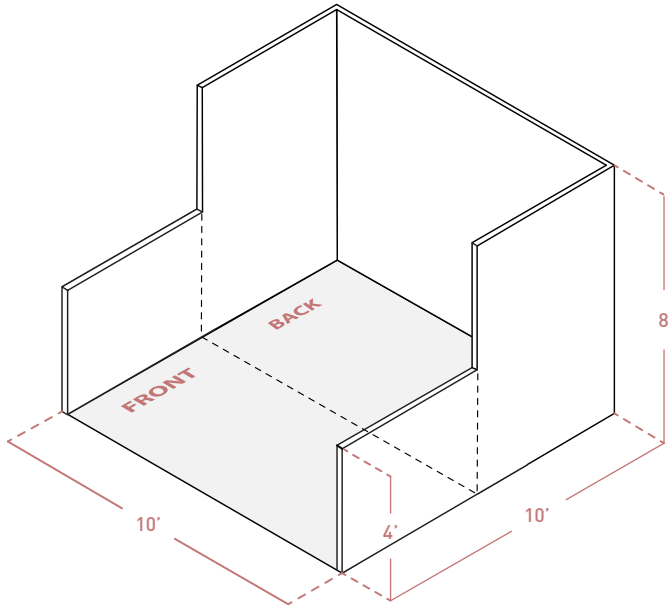

- A Front half fixtures max height 4'
- B Back half fixtures max height 8'

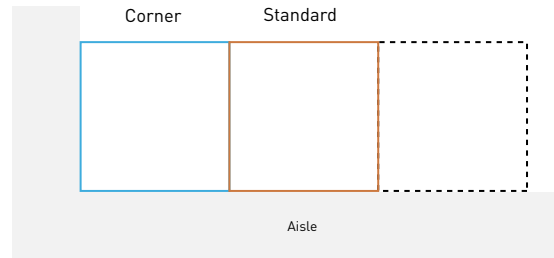

Height

Exhibit fixtures, components and identification signs will be permitted to a maximum height of 8' (2.44m).

Intent: If a portion of an exhibit booth extends above 8' (2.44m) high, the exhibit booth background will detract from the overall impact of the exhibit directly behind that booth regardless of how the rear of the offending exhibit is finished.

Depth

All display fixtures over 4' (1.22m) in height and placed within 10 lineal feet (3.05m) of an adjoining exhibit must be confined to that area of the exhibitor's space which is within 5' (1.52m) of the back line.

Intent: Each exhibitor is entitled to a reasonable sight line from the aisle regardless of the size of exhibit. Exhibitors with larger space—30 lineal feet (9.14m) or more—should also be able to effectively use as much of the total floor space as possible as long as they do not interfere with the rights of others. The limitation on display fixtures over 4' (1.22m) and within 10 lineal feet (3.05m) of a neighboring exhibit is intended to accomplish both of these goals.

IMPORTANT Space dimensions shown on floor plan are from center line of booth equipment, such as side rails and/or back drape. Exhibit structures must be constructed to allow sufficient tolerance on each side for this equipment and for utility service at rear of booth.

Perimeter Wall Booth

Exhibit in units located on the outer-perimeter wall of the exhibit floor.

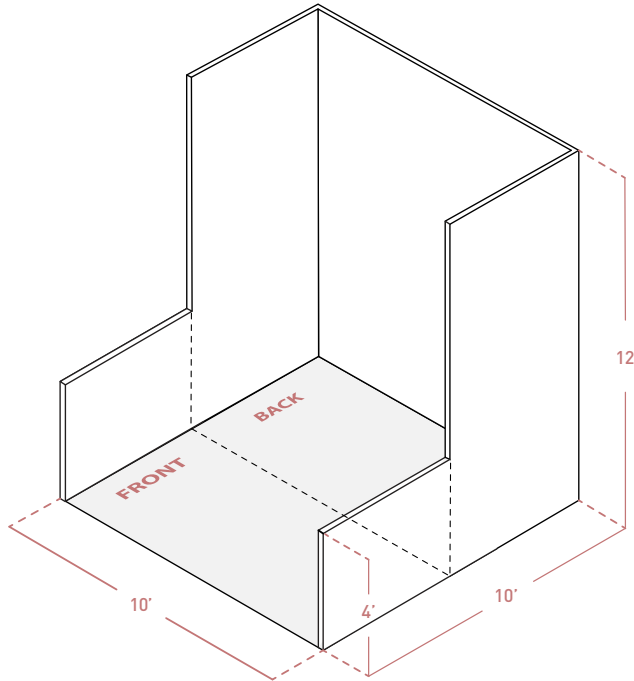

A Front half fixtures max height 4'

B Back half fixtures max height 12'

Height

Exhibit fixtures, components and identification signs will be permitted to a maximum height of 12' (3.65m) in perimeter-wall booths, unless otherwise limited by the convention center.

Intent: Because the outer perimeter booths are not backed up against another exhibitor's booth, display back walls and materials over 8' (2.44m) will not interfere with or distract from any other exhibit booth.

Depth

All display fixtures over 4' (1.22m) in height and place within 10 lineal feet (3.05m) of an adjoining exhibit must be confined to that area of the exhibitor's space which is within 5' (1.52m) of the back line.

Intent: Each exhibitor is entitled to a reasonable sightline from the aisle regardless of the size of exhibit. Exhibitors with larger space—30 lineal feet (9.14m) or more—also should be able to effectively use as much of the total floor space as possible, as long as they do not interfere with the rights of others. The limitation on display fixtures over 4' (1.22m) and within 10 lineal feet (3.05m) of a neighboring exhibit is intended to accomplish both of these goals.

NOTE: We suggest that exhibitors considering a perimeter-wall booth in order to take advantage of the extra height permitted should design their exhibit so it can be used at the 8' (2.44m) height and the 12' (3.65m) height so it can be used in all future shows, even if a perimeter-wall space is not available.

IMPORTANT Space dimensions shown on floor plan are from center line of booth equipment, such as side rails and/or back drape. Exhibit structures must be constructed to allow sufficient tolerance on each side for this equipment and for utility service at rear of booth.

Exhibit exposed to aisles on all four sides.

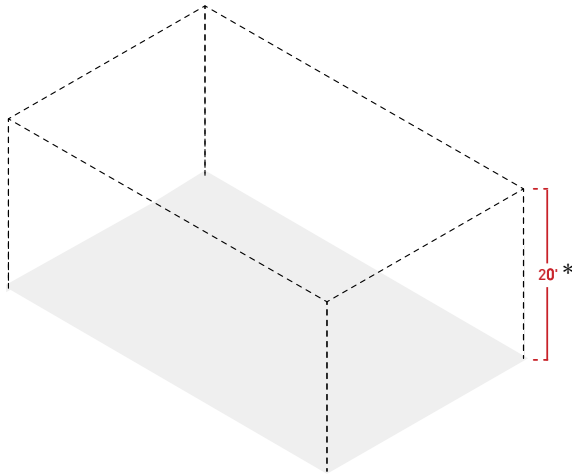

👁 The entire cubic content of the space may be used up to the maximum allowable height.

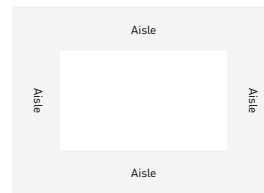

Height

Exhibit fixtures, components and identification signs will be permitted to a maximum height of 20' (6.096m) in island booths unless otherwise limited by the convention center's low ceiling areas.

Intent: When an island booth exceeds 8' (2.44m), it does not interfere with other exhibitors because it obviously does not back up against another exhibitor's back wall. The extra height is often required in an island booth exhibit to permit the open walk-through approach normally used in this type of location.

Depth

Because an island booth is automatically separated by the width of an aisle from all neighboring exhibits, full use of the floor plan is permitted.

Side Walls

The entire cubic content of the space may be used up to the maximum allowable height.

Structural Integrity

All multi-story exhibits, regardless of whether people will occupy the upper area or not, must provide drawings for inspection at least 60 days prior to the show by Show Management, the installation and dismantling contractor, the exhibitor and governmental authority during the time the exhibit is being erected, exhibited and dismantled at the show site. All such exhibits also must include a signature or stamp of a reviewing structural engineer indicating that the structure design is properly engineered for its proposed use, and a signature of an authorized official of the exhibit building company indicating that the structure is built in compliance with the details and specifications set forth on the drawings.

Signs also must be posted indicating the maximum number of people the structure will accommodate.

Low Ceiling Areas

The maximum height in low ceiling areas is 15' and rigging is prohibited.

Intent: Exhibitors in the vicinity of island exhibits are entitled to the same reasonable safety precautions they would expect if they were adjacent to a standard booth.

*Unless otherwise limited by convention center low ceiling areas.

🚫 IMPORTANT Exhibitors are cautioned when installing a display with a ceiling or second level to check with Show Management to insure that their display meets the necessary fire safety precautions involving smoke alarms, fire extinguishers, sprinkler systems, etc.

An exhibit that is covered in part or whole.

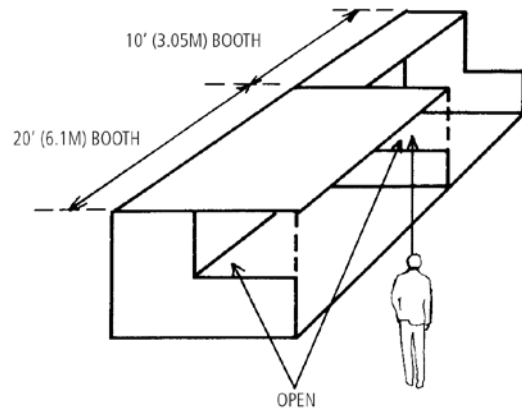
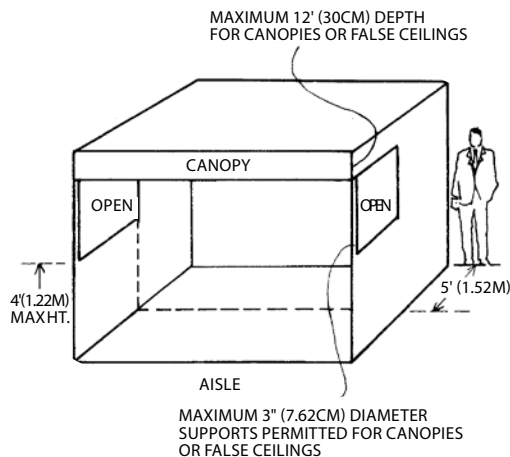

Height

Canopies, false ceilings and umbrellas will be permitted to a height that corresponds to the height regulation for the appropriate exhibit configuration of which they are a part. For example, canopies will not exceed 8' (2.44m) in height in a standard booth configuration. Furthermore, the canopy or false ceiling will not exceed 1' (30cm) in depth.

Intent: Exhibitors requiring canopies or false ceilings to create the desired exhibit environment within their booth space should be allowed to do so as long as the canopy and its support structure do not violate the intent of the height or depth regulation.

Depth

Canopies may extend out to the aisle line and up to the booth line on either side of an exhibitor's space, providing that the support structure will not exceed 3" (7.62cm) in width when placed within 10 lineal feet (3.05m) of an adjoining exhibit and not confined to that area of the exhibitor's space which is within 5' (1.52m) of the back line.

Intent: Exhibitors adjoining exhibits with canopies are entitled to the same reasonable sight line from the aisle as they would expect if they were adjacent to an exhibitor with a standard booth.

IMPORTANT Exhibitors are cautioned when installing a display with a ceiling or covered booth to check with Show Management to insure that their display meets the necessary fire safety precautions involving smoke alarms, fire extinguishers, sprinkler systems, etc.

A free-standing exhibit component separate from the main exhibit fixture that is used for identification and display purposes only.

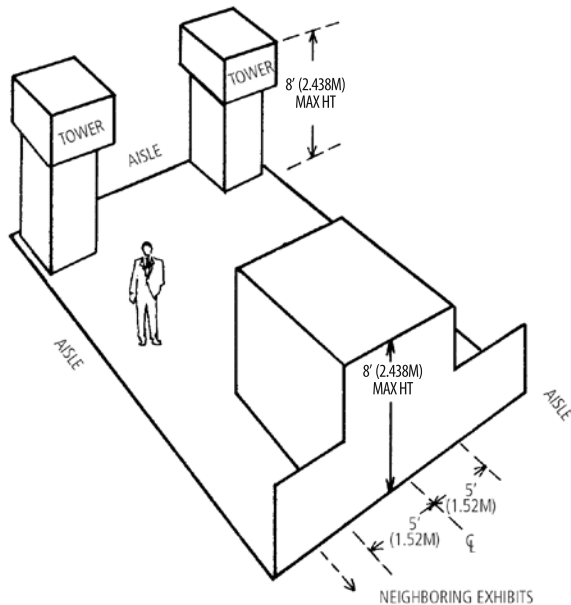

Height/Depth

Towers will be permitted to a height and depth that correspond to the height and depth regulations for the appropriate exhibit configuration of which they are a part. For example, towers that are part of a peninsula exhibit consisting of two corners and two standard booths will not exceed 8' (2.438m) in height, and will not be placed within 10 lineal feet (3.05m) of a neighboring exhibit to avoid blocking the sight line from the aisle to the adjoining booth.

Intent: Towers are part of the overall exhibit presentation and, therefore, must be treated as a component of the total exhibit configuration. The maximum height and depth regulations have been set to assure neighboring exhibitors the same reasonable sight line from the aisle as they would expect if they were adjacent to an exhibitor with a standard booth.

Structural Integrity

All towers in excess of 10' (3.05m) must have drawings available for inspection by exposition management, the installation and dismantling contractor, the exhibitor and governmental authority during the time the tower is being erected, exhibited and dismantled at the show site that include a signature or stamp of a reviewing structural engineer indicating that the structure designed is properly engineered for its proposed use, and a signature of an authorized official of the exhibit building company indicating that the structure is built in compliance with the details and specifications set forth on the drawings.

Intent: The structural integrity of towers must be ensured in the overall interests of safety.

Hanging Signs

An exhibit component suspended above an island exhibit for the purpose of displaying graphics or identification.

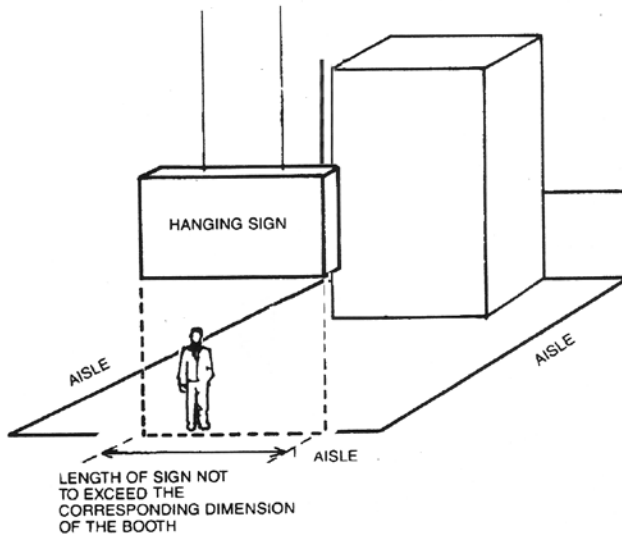

Height/Weight

Hanging identification signs and graphics will be permitted with a maximum height of the given booth's height specifications unless booth is in a convention center low ceiling area in which rigging is prohibited..

Intent: Hanging signs are part of the overall exhibit presentation and therefore must be treated as a component of the total exhibit configuration. All signs, whether suspended or attached to the exhibit fixture, will be permitted to a maximum height that corresponds to the appropriate exhibit configuration.

Size

Hanging signs and graphics will be permitted to a total length on each side of the exhibitor's space, but may not over hang the aisle.

Structural Integrity

All hanging signs must have drawings available for inspection by exposition management, the installation and dismantling contractor, the exhibitor and governmental authority during the time the component is being hung, suspended and removed at the show site that include a signature or stamp of a reviewing structural engineer indicating that the stress points for hanging the sign have been properly engineered, and a signature of an authorized official of the exhibit building company indicating that the structure is built in compliance with the details and specifications set forth on the drawings.

NOTE: Exhibitors are encouraged to use lightweight materials in the construction of a hanging sign to eliminate excessive stress to the facility ceiling structure.

Intent: The structural integrity of the sign, its means of suspension and anchoring systems must be ensured in the overall interest of safety.

NOTE: Any hanging items from the ceiling such as signs and graphics must be pre-approved by Show Management at least 60 days prior to the exposition. Hanging signs are prohibited in low ceiling areas.